

60ML VARIABLE AUTOMATIC DRENCHER MKIII



IMPORTANT: The Phillips 60ml Automatic Drencher (referred to as instrument) has been designed for oral administration to livestock of most solutions and suspensions within its dose range. As components in this instrument may be affected by solvents in some "pour-on" formulations no responsibility will be accepted by the manufacturer should the instrument be used with such products.

BEFORE DRENCHING: Always read the label.

Check the label on the pharmaceutical manufacturer's container for dose rates, precautions, and safety information prior to use.

Use only the recommended dose rate.

Use only the pharmaceutical manufacturer's recommended rates. Refer to the pharmaceutical manufacturer's dose rate chart or specification. NJ Phillips Pty Limited will take no responsibility if the instrument is used for any other purpose than specified or used contrary to the pharmaceutical manufacturer's dose rate specifications.

Check the instrument.

Before each use, the nozzle should be inspected to ensure there are no sharp edges. Should this occur, remove with file or emery paper or replace nozzle.

INSTRUCTIONS FOR USE: Drenching

1. Fit one end of the feed tube to the adaptor of the back pack, or to the draw off tube, if a non-collapsible container is being used. Fix the tube by screwing the spring provided, in an anticlockwise direction over the tube and adaptor. This will also prevent kinking of the feed tube at this point.
2. If using backpack with different size connection, connect large bore feed tube (1) as shown in diagram below, to plastic adaptor (2), then attach plastic adaptor to draw off cap using 3/4" feed tube (3) and spring (4).
Fit other end of tube to the inlet adaptor of the instrument, in a similar manner.

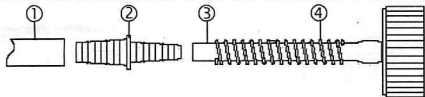

WARNING: Care must be taken to ensure the liquid does not come into contact with any part of the operators body. Chemicals may cause injury to the operator.

3. Prime the hand piece by squeezing the lever several times until an unbroken flow of liquid passes from the nozzle. The instrument must be held vertically, with the nozzle pointed upwards, to ensure the instrument is fully primed.

4. Set the required dose by aligning the front of the piston with the dose marking on the cylinder.

The diagram on the right shows the front of the piston aligned with the 35ml dose marking on the cylinder. This is the correct placement of the piston for a 35ml dose.

Refer to "To Adjust the Dose" section below.

5. Before use and after priming each new container, measure the dose to ensure it is correct.

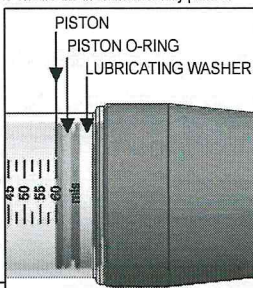

CAUTION: Always exercise care when dosing animals. Do not apply undue pressure and ensure the nozzle is not forced against or through delicate mouth and throat tissues.

Calibration of the Instrument: As the graduation markings on the item 8 (cylinder) are for reference only, check the accuracy of the instrument with a calibrated measuring cylinder (these are available for purchase from njphillips.com). To ensure repeatability, squirt 2 x 20ml doses into a calibrated glass. The level of fluid should be at the 40ml mark. If it is not, readjust the instrument following the steps above then perform the dose test again. If you have problems with dose accuracy contact the manufacturer or place of purchase.

To Adjust the Dose: Adjust the dose by turning item 24 (dose adjustor) clockwise for smaller doses, and anticlockwise for larger doses. To set the correct dose, align the front of item 12 (black piston) with the cylinder marking.

Drenching Position: For best operating results the container should be at about the same height as the instrument when in use. Should the container be at a much lower level than the instrument, the refill rate will slow down between doses.

CARE AND MAINTENANCE: Before Drenching

As lubricants will evaporate during storage, before using, it is important to run a few drops of lubricant into the push rod, with the nozzle of the hand piece pointing downwards. This will allow the lubricant to run into the cylinder and lubricate the piston.

Ensure that all equipment is thoroughly clean before use, by flushing with water. Before each use the nozzle should be inspected to ensure plating is not damaged or worn to a sharp edge. Should this occur, remove with file or emery paper or replace nozzle.

After Drenching: Where suspension type drenches have been used it is advisable to flush the complete equipment with a water detergent mix. This should be followed by clean water.

Solution type drenches normally require a thorough flushing with clean water.

All moving parts should be lubricated before storage.



IMPORTANT: DO NOT store your applicator or feed tube full of product. Clean as per the "Care and Maintenance" instructions.

Sterilizing: A common method of sterilization is as follows:

1. Connect feed tube and spring to hand piece.
2. Wrap cloth around hand piece and place end of feed tube into container of clean hot water and draw hot water into cylinder by depressing lever. It is most important the cylinder is full of water before suspending in container. If this is not done, the steam created by sterilizing can crack the cylinder.
3. Remove cloth and suspend complete instrument by fully immersing in a container of water and boil for 10 to 20 minutes.



NOTE: Suspending the instrument not only makes it easier to remove, but also prevents damage should the container boil dry. Chemical sterilization with antiseptic solutions is sometimes practised and in such instances the recommendations of the chemical manufacturer should be followed. DO NOT attempt to sterilize by autoclaving.

4. Remove instrument from container, wrap cloth around handle and pump dry, remove cloth and dry hand piece.

Attach connecting tube to both the hand piece and draw off system. Make sure the springs provided are screwed over the feed tube in an anti-clockwise direction. This will prevent the tube from kinking at these points.

- | | | |
|----------------------------|-----------------------------|---------------------------------|
| 1. Nozzle Lock Nut | 11. Piston O-ring | 21. Body Plug |
| 2. Cattle Nozzle | 12. Piston | 22. Dose Adjustor Sleeve |
| 3. Nozzle Seal Ring | 13. Lubricating Washer | 23. Dose Adjustor Washer Spring |
| 4. Delivery Valve Spring | 14. Piston Seal Ring | 24. Dose Adjustor |
| 5. Delivery Valve | 15. Push Rod | 25. Return Spring |
| 6. Delivery Cage Lock Nut | 16. Inlet Adaptor Seal Ring | 26. Lever Pad |
| 7. Cylinder Shield Cap | 17. Inlet Valve Spring | 27. Lever |
| 8. Cylinder | 18. Inlet Valve | 28. Lever Pin |
| 9. Delivery Cage Seal Ring | 19. Inlet Adaptor | |
| 10. Delivery Cage | 20. Handle | |

PLEASE ORDER BY KIT AND PART NAME.

Parts not included in Minor or Major Service Kits may be available for individual purchase.

KIT No.	PART NAME	INCLUDES	ILLUSTRATION No.
WX1331	Major Service Kit	3,4,5,8,9,11,12,13,14,16,17,18,26,28.	
WX1330	Minor Service Kit	3,4,5,9,11,12,13,14,16,17,18.	

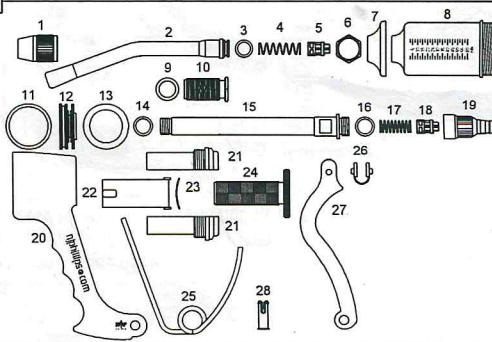

IMPORTANT: QUICK REFERENCE TROUBLESHOOTING GUIDE

SYMPTOM	PROBABLE CAUSE	CORRECTIVE ACTION
1a. Product being returned to the container from the instrument.	Foreign matter lodged under the inlet valve.	SEE A. Remove inlet adaptor (19) and clean the internal seat by removing valve (18) and spring (17), rinse with clean water then wipe with a soft cloth. Reassemble ensuring correct orientation of the valve (18) and spring (17).
	1b. Unable to draw product from the container.	SEE B. Replace inlet valve spring (17).
	The inlet valve and spring are incorrectly assembled.	SEE C. Reassemble the valve (18) and spring (17) correctly (as shown in the photo A).
2. Product leaking out of the nozzle or air being drawn into the cylinder from the nozzle end.	Foreign matter lodged under delivery valve.	SEE D. Remove nozzle (2), valve and spring (4). Clean valve seat located in front of cylinder by rinsing and wiping with a soft cloth. Clean valve and spring (4) and reassemble ensuring valve and spring are oriented correctly.
	Nozzle seal ring is damaged.	SEE E. Replace nozzle seal ring (3).
	Delivery valve and spring are incorrectly assembled.	SEE E. Reassemble valve (5) and spring (4) correctly (see parts illustration).
	Delivery valve sealing edge damaged.	SEE F. Replace the delivery valve (5) and spring (4).
3. Fluid dripping out of nozzle when not in use.	Delivery cage seal ring damaged.	Replace the delivery cage seal ring (9).
	Instrument is hanging at end of feed tube when not in use.	SEE G. Hang instrument at same height or higher than off take point of feed tube on container of product. This ensures the delivery valve is free of load which can cause the product to leak past the valve assembly.
4. Air is being drawn into the cylinder from in and around the piston.	Foreign matter lodged on or around piston o-ring.	SEE H. Replace piston o-ring (11) and lubricate liberally.
	Piston not sealing against push rod.	SEE H. Remove cylinder (8). Hold rear push rod (15), tighten piston (12) firmly using wide blade screwdriver in slot or replace push rod / piston seal ring (if applicable).
	Delivery valve and spring incorrectly assembled.	SEE E. Reassemble valve (5) and spring (4) correctly (see parts illustration).
	Feed tube perforated /damaged.	Replace the feed tube.
	Feed tube connection at container or instrument is split or damaged.	Replace container fitting or inlet adaptor to ensure an air tight seal. Cut feed tube for clean ends.
	5. Piston not returning fully on filling stroke.	Piston o-ring and lubricating washer are dry.
Blockage in inlet line.		Check inlet valve (18) and spring (17), inlet adaptor (19), feed tube and container draw off fitting for foreign matter.
Kinking or restriction of feed tube.		Remove restriction or reposition feed tube.
Binding of push rod within dose adjustor assembly caused by foreign matter lodged between sliding surfaces.		Dismantle push rod (15) from instrument and rinse it and dose adjustor assembly with clean water. Inspect for damage. If damaged, replace affected part.
Material used too viscous for draw-off and feed tube.		Increase feed tube and draw off bore size.
Chemical container not collapsing as instrument draws fluid.		Vent pack or use a Phillips Vented Draw-Off system.
6. Hard delivery stroke pressure		Foreign matter in delivery valve spring or blockage in nozzle.

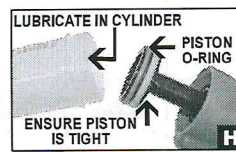
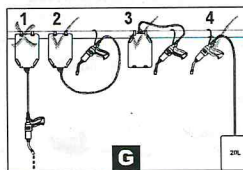
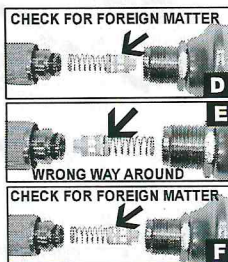
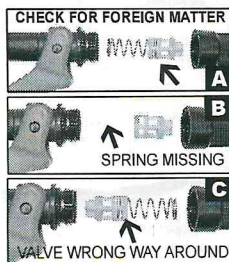

NJ PHILLIPS PTY LTD ABN 36 000 082 002 **MADE IN AUSTRALIA**
ADDRESS: LOCKED BAG 8, GOSFORD, NSW 2250 AUSTRALIA
TELEPHONE: +61 2 4340 2044 **FAX:** +61 2 4340 1991 **EMAIL:** njp1@njphillips.com.au



njphillips.com
Our expertise is in your hands.

AS OUR POLICY IS ONE OF CONTINUOUS IMPROVEMENT THE MANUFACTURER RESERVES THE RIGHT TO ALTER THESE SPECIFICATIONS AT ANY TIME. ALL PRODUCTS PRODUCED BY NJ PHILLIPS PTY LIMITED, ARE IDENTIFIED BY A UNIQUE BATCH NUMBER. THIS IDENTIFICATION NUMBER IS AFFIXED TO THE PRODUCT TO ALLOW TRACEABILITY BY THE MANUFACTURER AND MUST NOT BE REMOVED IF PRODUCT INTEGRITY IS TO BE MAINTAINED.

PAD826 | Q1